



Office of Statewide Health Planning and Development
ANCHORAGE PRE-APPROVAL

OPA-2098-07

Equipment Manufacturer: Belimed, Inc.

Equipment Type: WD290

GENERAL NOTES

1. EXPANSION ANCHORS:

(a) ATTACHMENT IS TO BE MADE WITH THE ANCHORS LISTED BELOW AND INSTALLED AS DESCRIBED IN THE CORRESPONDING ICC REPORT.

Anchor Diameter	Concrete Type	Min. f'c (psi)	Anchor Type	ICC Report No.	Min. Embed.	Min. Spacing	Min. Edge Dist.	Min. Conc. Thickness	Installation. Torque	Test Loads
1/2"	Hardrock	3000	Hilti Kwik Bolt TZ	ESR-1917	3-1/4"	12"	18"	6"	40 FT-LBS	Direct Pull Tension - 3750 lbs

(b) THIS PRE-APPROVAL ALLOWS FOR UP TO A MAXIMUM OF 2 ADJACENT CONCRETE SLAB EDGES, 18" AWAY MINIMUM (i.e. - CORNER). SEE ADJACENT DETAIL FOR ADDITIONAL MINIMUM ALLOWABLE CONCRETE EDGE DISTANCES.

2. TESTING OF EXPANSION ANCHORS PER 2007 CBC, 1916A-8 : TENSION TESTING SHALL BE DONE IN THE PRESENCE OF THE SPECIAL INSPECTOR AND A REPORT OF THE TEST RESULTS SHALL BE SUBMITTED TO OSHPD

- (a) AFTER AT LEAST 24 HOURS HAVE ELAPSED SINCE INSTALLATION, DIRECT PULL TENSION TEST AT LEAST 50% OF THE ANCHORS.
- (b) ACCEPTANCE CRITERIA: THE ANCHOR SHOULD HAVE NO OBSERVABLE MOVEMENT AT THE TEST LOAD. A PRACTICAL WAY TO DETERMINE OBSERVABLE MOVEMENT IS THAT THE WASHER BECOMES LOOSE.
- (c) IF ANY ANCHOR FAILS, TEST ALL ANCHORS.

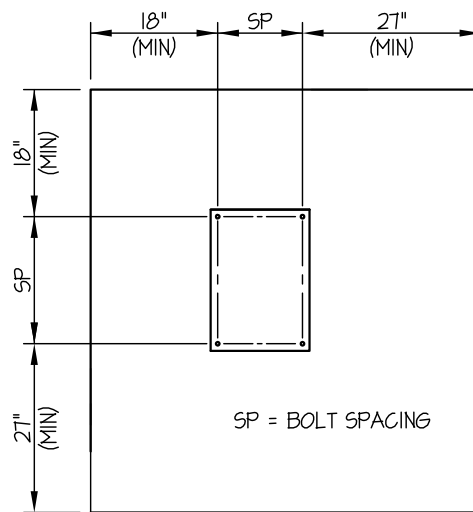

TYPICAL CONCRETE EDGE DETAIL



A P P R O V E D
Fixed Equipment Anchorage
 Office of Statewide Health Planning and Development

OPA-2098-07

Pre-approval Program Manager:
 Anthony R. Pike
 (916) 440-8470



Anthony R. Pike
 Reviewed By: Anthony R. Pike 10/7/10



EASE
EQUIPMENT ANCHORAGE & SEISMIC ENGINEERING
2801 Connery Way Suite B
Missoula, MT 59808
Phn: (406) 541-3273 Fax: (406) 541-3274

Office of Statewide Health Planning and Development
ANCHORAGE PRE-APPROVAL

OPA-2098-07

Equipment Manufacturer: Belimed, Inc.

Equipment Type: WD290

GENERAL NOTES (CONTINUED)

3. FORCES PER ASCE 7-05 SECTION 13.3.1, EQUATIONS 13.3-1, 13.3-2 & 13.3-3, WHERE $S_Ds = 1.93$, $a_p = 2.5$, $I_p = 1.5$ & $R_p = 6.0$
4. THIS PRE-APPROVAL CONFORMS TO THE 2007 CALIFORNIA BUILDING CODE.
5. THE DETAILS IN THIS PRE-APPROVAL MAY BE USED AT ANY LOCATION IN THE STATE OF CALIFORNIA.
THE ELEVATED FLOOR DETAILS MAY BE USED AT ANY HEIGHT IN A BUILDING.
6. ALL ANCHOR FORCES SHOWN ON THE DRAWINGS ARE WORKING LOADS (AS OPPOSED TO STRENGTH LEVEL LOADS)
AND MAY BE USED FOR ALLOWABLE STRESS DESIGN.
7. THIS PRE-APPROVAL COVERS THE ANCHORAGE OF THE UNIT ONLY.

RESPONSIBILITIES OF THE STRUCTURAL ENGINEER OF RECORD

8. VERIFY THAT THE CONCRETE SLAB WHICH THE EQUIPMENT IS ANCHORED TO IS NOT CRACKED.
9. VERIFY THAT THE ANCHORS ARE AN ADEQUATE DISTANCE FROM ANY SLAB EDGES OR OPENINGS (SEE TYPICAL DETAIL ON SHEET 1).
10. VERIFY THAT ALL NEW OR EXISTING ANCHORS ARE AN ADEQUATE DISTANCE FROM THE ANCHORS SHOWN ON THIS PRE-APPROVAL.
IN NO CASE SHALL THIS UNIT'S ANCHORS BE WITHIN THE LESSER OF $3x$ EDGE DISTANCE SHOWN ON TYPICAL CONCRETE EDGE DETAIL (SHEET 1) OR 18" FROM ANY NEW OR EXISTING ANCHORS.
11. DESIGN BACKING BARS, STUDS, ETC. WHICH THE UNITS ARE ATTACHED TO AS NOTED ON THE DRAWINGS.
THE SEOR SHALL ALSO VERIFY THE ADEQUACY OF THE STRUCTURES (SUCH AS WALLS AND FLOORS)
WHICH SUPPORT THE UNITS FOR THE LOADS IMPOSED ON THEM BY THE UNITS AS WELL AS ALL OTHER LOADS.
12. PROVIDE ANY SUPPORTING STRUCTURE REQUIRED TO SUPPORT WEIGHTS AND FORCES SHOWN, IN ADDITION TO ALL OTHER LOADS.
13. VERIFY THAT THE INSTALLATION IS IN CONFORMANCE WITH THE 2007 CBC AND WITH THE DETAILS SHOWN IN THIS PRE-APPROVAL.
VERIFY THAT THE ACTUAL EQUIPMENT'S WEIGHT, CG LOCATION, ANCHOR LOCATIONS, ANCHOR DETAILS AND THE MATERIAL AND GAGE OF THE UNIT WHERE ATTACHMENTS ARE MADE AGREE WITH THE INFORMATION SHOWN ON THE PRE-APPROVAL DOCUMENTS.

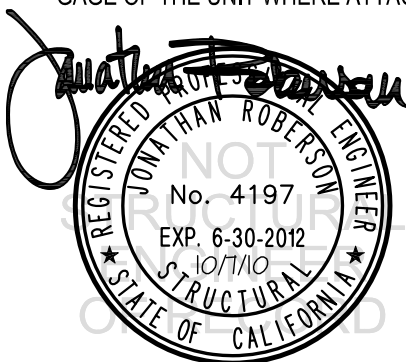

BELIMED, INC.

WD290

DES. **R. LA BRIE**

JOB NO. **11-0890**

DATE **10/7/10**

SHEET

3

OF **4** SHEETS

SEISMIC ANCHORAGE

SLAB ON GRADE

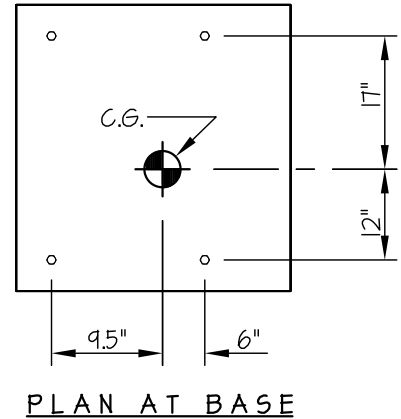
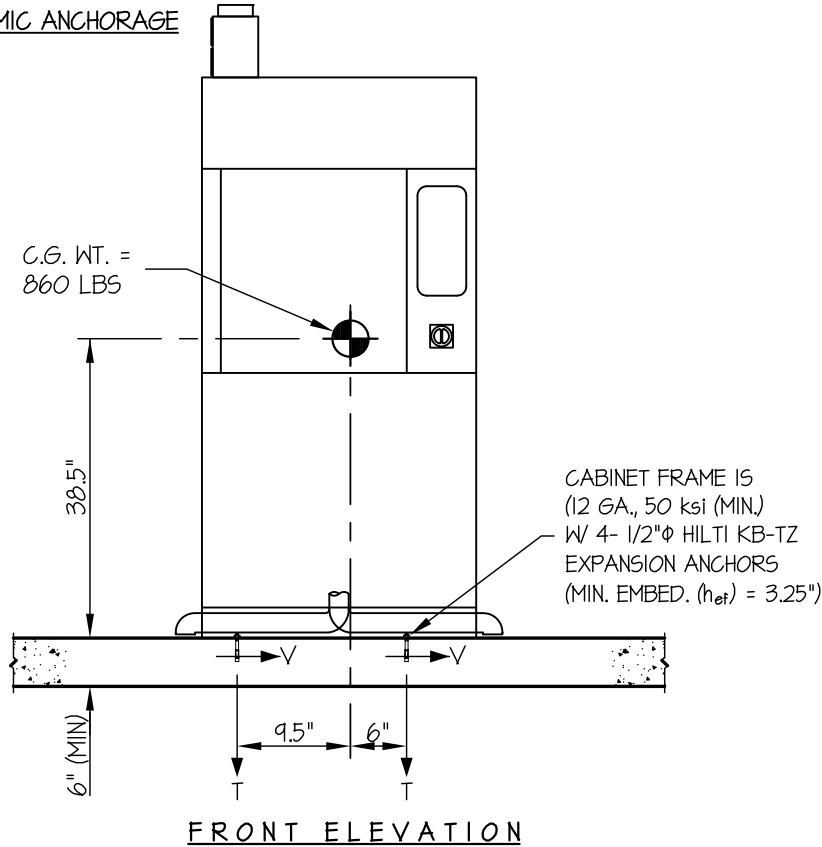

$T_{MAX} = 790$ LBS/BOLT
 $V_{MAX} = 322$ LBS/BOLT

NOTES:

1. ANCHORAGE DESIGN PER 2007 CALIFORNIA BUILDING CODE - SECTION 1613A AND ASCE 7-05 SECTIONS 12 AND 13. ALLOWABLE STRESS DESIGN IS USED.

HORIZONTAL FORCE (E_h) = $0.61 W_p$ ($S_{DS} = 1.93$, $a_p = 2.5$, $I_p = 1.5$, $R_p = 6.0$)

VERTICAL FORCE (E_v) = $0.27 W_p$

2. CENTER OF GRAVITY (C.G.) WEIGHT IS A MAXIMUM. THIS PRE-APPROVAL ENCOMPASSES ALL WEIGHTS UP TO THE MAXIMUM WEIGHT SHOWN.

3. ENGINEER OF RECORD FOR THE BUILDING SHALL PROVIDE SUPPORT STRUCTURE DESIGNED TO SUPPORT WEIGHTS AND FORCES SHOWN, IN ADDITION TO ALL OTHER LOADS.

4. SEE GENERAL NOTES: SHEETS 1-2



A P P R O V E D
Fixed Equipment Anchorage
Office of Statewide Health Planning and Development

OPA-2098-07
Pre-approval Program Manager:
Anthony R. Pike
(916) 440-8470

Anthony R. Pike
Reviewed By: Anthony R. Pike 10/7/10

BELIMED, INC.

WD290

DES. **R. LA BRIE**

JOB NO. **11-0890**

DATE **10/7/10**

SHEET

4

OF **4** SHEETS

SEISMIC ANCHORAGE

ELEVATED FLOOR

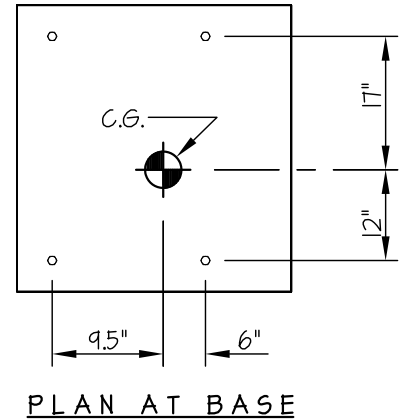
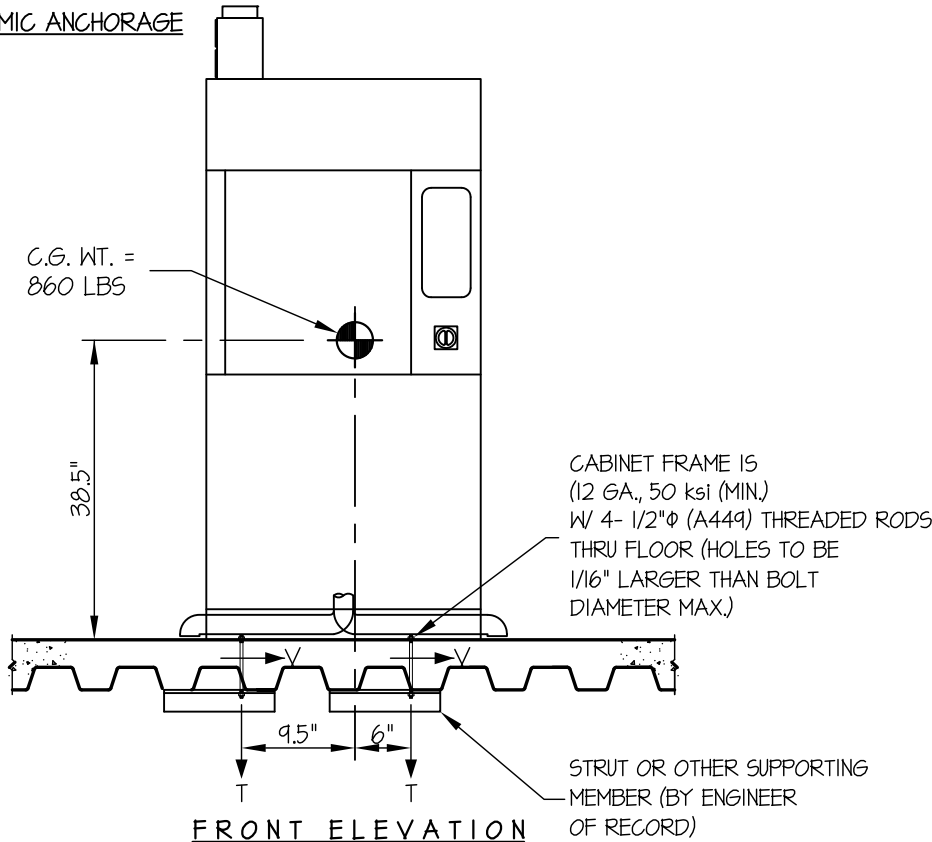

T_{MAX} = 1375 LBS/BOLT
 V_{MAX} = 533 LBS/BOLT

NOTES:

1. ANCHORAGE DESIGN PER 2007 CALIFORNIA BUILDING CODE - SECTION 1613A AND ASCE 7-05 SECTIONS 12 AND 13. ALLOWABLE STRESS DESIGN IS USED.
 HORIZONTAL FORCE (E_H) = 1.01 W_p (S_{DS} = 1.93, a_p = 2.5, I_p = 1.5, R_p = 6.0)
 VERTICAL FORCE (E_v) = 0.27 W_p
2. CENTER OF GRAVITY (C.G.) WEIGHT IS A MAXIMUM. THIS PRE-APPROVAL ENCOMPASSES ALL WEIGHTS UP TO THE MAXIMUM WEIGHT SHOWN.
3. ENGINEER OF RECORD FOR THE BUILDING SHALL PROVIDE SUPPORT STRUCTURE DESIGNED TO SUPPORT WEIGHTS AND FORCES SHOWN, IN ADDITION TO ALL OTHER LOADS.
4. SEE GENERAL NOTES: SHEETS 1-2

