

APPLICATION:

Provides deionized water for washers, disinfectors, glassware washers, steam boilers and final rinses.

DESCRIPTION:

Exchange deionizer system providing 200,000 ohm-cm minimum quality water. On-board recirculation pump with on/off switch keeps the water moving, which helps maintain high quality water at all times. Includes carbon/sediment prefilter and worker/polisher mixed bed deionizer packs. Flow rate is 1-3 GPM. Cart mounted with casters.

FEATURES:

- Carbon block / sediment prefilter
- Temperature compensated 200,000 ohm-cm monitor with alarm and 12 volt plug in transformer
- Two PVC columns for ½ cubic foot replaceable resin or carbon packs
- Pressure regulator with gauge
- Recirculation pump



CERTIFICATIONS:

- ISO13485 registered device
- FDA cleared for market

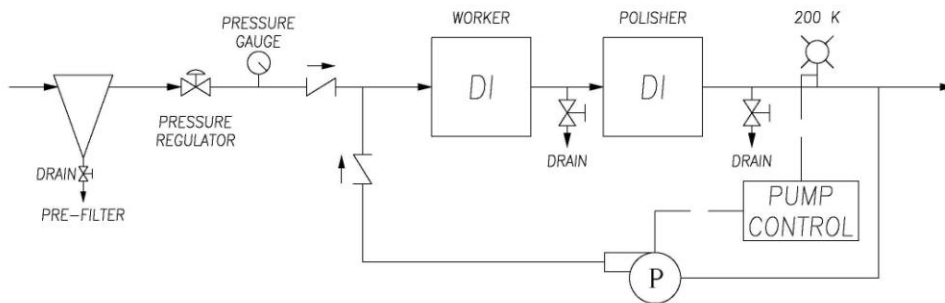

PRINCIPLE OF OPERATION:

Tap water enters the Silex Deionizer System through the pressure regulator and gauge set at 50 PSIG to the high efficiency 10 micron carbon block prefilter. The dechlorinated water then flows through the first deionizer column, then to the second column, and exits through the 200,000 ohm-cm set point resistivity monitor with alarm. The pump keeps the water recirculating to assure high quality water at all times. When the green light illuminates, the quality is above 200,000 ohms-cm. When the red light illuminates, it indicates that the deionizer packs need to be exchanged and returned for regeneration by shipping ground parcel (UPS / FedEx standard shipping).

SAFETY FEATURES:

- Inlet pressure regulator prevents inlet pressures above 50 PSIG.
- Deionizer bottom 0.007" slotted distributors prevent resin from exiting the system.

INPUT REQUIREMENTS:

Floor Space	24" wide x 17" deep
Feed Water Quality Requirement	EPA drinking water standards
Inlet Water Temperature	100°F Maximum
Inlet Water Pressure	> 10 PSIG
Electrical	115V, 3 Prong Receptacle

SPECIFICATIONS / PERFORMANCE:

Shipping Weight	150 lbs
Operation Weight	106 lbs
GPM Flow Rate	3 GPM
Output Water Quality	> 200,000 ohms

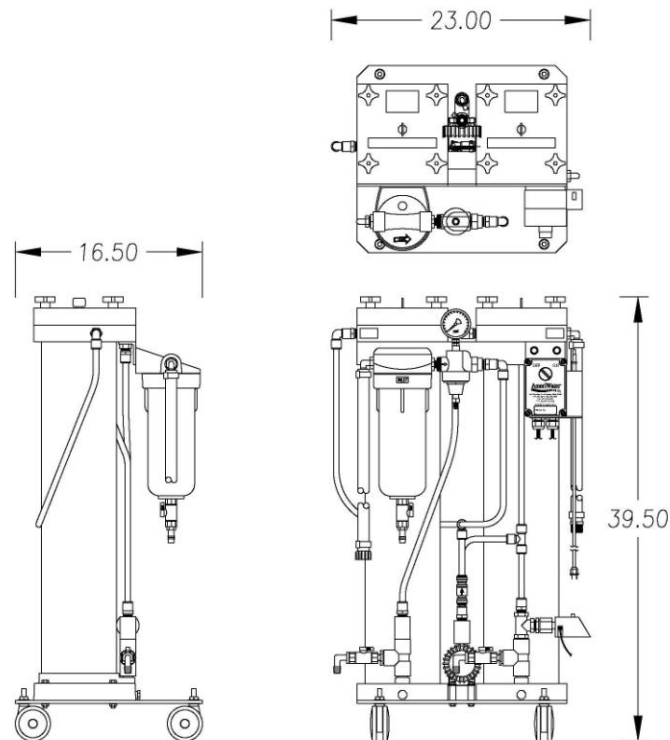

WARRANTY:

One year on parts.

ACCESSORIES:

Description	Part Number
Post Filter Assembly	0119-0023
Carbon Filter Cartridge	20-5101
Deionizer Resin Pack	002101S
Remote Alarm Module	75679124
Remote Alarm Cable 50 Ft.	7569125
Remote Alarm Cable 100 Ft.	75RPC-100
Remote Alarm Cable 200 Ft.	75679131